

REVISIONS			
REV.	DESCRIPTION	DATE	ECN
A	INITIAL RELEASE	5/7/09	1179
B	TOLERANCE CHANGE	5/21/09	1186
C	UPDATE TO CURRENT FORMAT	6/3/10	1316

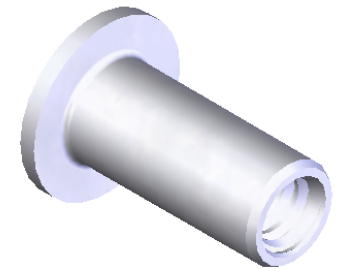
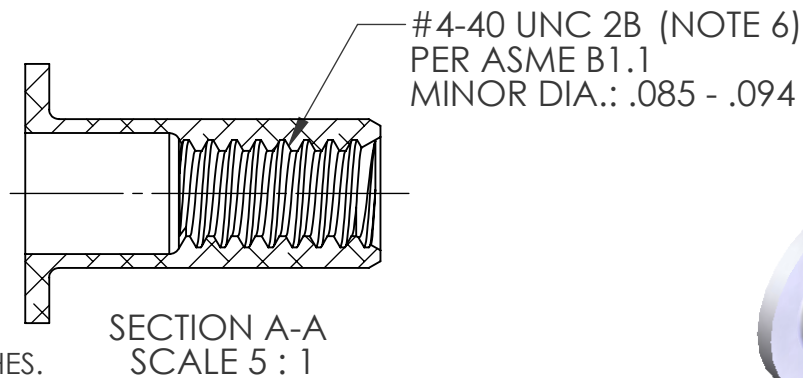

NOTE:

- GRIP RANGE: .010 - .060
- HOLE SIZE: .156 +.002/-.000 AFTER ALL APPLIED FINISHES.
- INSTALLED LENGTH: .230 REF.
- LUBRICATION: NONE
- INSTALLATION TOOL: SPIN-PULL
- MAY BE PRODUCED TO 3B THREAD CLASS DEPENDING ON THE MANUFACTURING LOT NUMBER OR CUSTOMER REQUIREMENT. SPECIFIC CLASS AVAILABLE UPON REQUEST.

PROPRIETARY AND CONFIDENTIAL

THIS DRAWING, AND THE INFORMATION CONTAINED HEREIN, ARE THE PROPERTY OF SHEREX AND ARE NOT TO BE USED IN ANY MANNER DETRIMENTAL TO THE INTEREST OF THE COMPANY.
SHEREX SOLUTIONS RESERVES THE RIGHT TO REVISE PART/DRAWING WITHOUT NOTICE.

		UNLESS OTHERWISE SPECIFIED:	NAME	DATE
		DIMENSIONS ARE IN INCHES TOLERANCES: ANGULAR: MACH ± 1 BEND ± 1 TWO PLACE DECIMAL ± .01 THREE PLACE DECIMAL ± .002	DRAWN	TWR 5/7/09
		INTERPRET GEOMETRIC TOLERANCING PER: ASME Y14.5M-1994	CHECKED	
		MATERIAL	ENG APPR.	JVK 5/7/09
		A5056/6053-T4	MFG APPR.	
		FINISH	Q.A.	JVK 5/7/09
		NONE	COMMENTS:	
NEXT ASSY	USED ON		E-mail: info@sherex.com	
			www.sherex.com	
			Phone: 866-474-3739	
			Fax: 716-875-0358	
APPLICATION		DO NOT SCALE DRAWING		

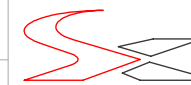

TITLE:

FLAT HEAD OPEN END

SIZE DWG. NO.

A CA-0440A-060

REV

C

SCALE: 2:1 WEIGHT: kg

SHEET 1 OF 1